

Click to watch Videos.....

What is F1 in Schools?

F1 in Schools World Finals 2019

VIRTUAL FINAL 2020/21

**RACING
OPTION 1**

**RACING
OPTION 2**

INTRODUCTION

Welcome to the world of F1 in Schools.....

F1 in Schools is a **STEM** (Science, Technology, Engineering, Mathematics) Competition, where teams of students follow the process of Research –Design –Analyse –Make –Test –Race to compete with their own miniature F1 cars.

Your challenge: Form a team and identify specific roles for each team member, then work collaboratively, as a team, to create the following items:

A team brand, logo and identity

Team uniform (apparel)

An aerodynamic F1 in Schools race car

A budget and team sponsorship presentation

100 Pitcoin Start-up fund: As a new team, you have been given a start-up fund of 100 PITCOIN (**PC**) to put towards project costs, which will start you off but won't be enough on its own. You'll need to raise more PITCOIN through gaining sponsorship and will have the opportunity to present your team to potential sponsors to gain their support for your team and earn vital PITCOIN to put towards the cost of manufacturing your car and producing team uniforms etc. Think carefully about how you can convince a sponsor that they should pay to put their logo on your car and team uniform ...

Prove yourselves:

Your team's learning journey through the process of the Mini Project should be presented in a Portfolio of Work, including such things as Design & Development, Team Identity and Project Management.

At the end of this Mini Project, you will race your car against the other teams to find out who has designed and manufactured the fastest car – the overall winner!

There will be different **awards** and **prizes** on offer to reward the teams' hard work, so every team member must contribute equally to ensure the team as a whole performs at its best!

Job Roles and having fun: For your team to be a success, each team member must contribute equally and play to their strengths, so good Project Management is crucial!

Above all, F1 in Schools should be fun, so enjoy the challenge, do your best and work together as a team to support each other in any way you can. The most effective teams are the ones who really enjoy what they do and help each other achieve their goals

..... so welcome to **F1 in Schools!** Have fun finding your passion, we'll see you at the track...

TASK LOG

SESSION	TASKS	DATE	TEAM MEMBER	COMPLETED
1				
2				
3				
4				

SESSION	TASKS	DATE	TEAM MEMBER	COMPLETED
5				
6				
7				
8				

DESIGN BRIEF

Your task is to make, test and race a miniature F1® racing car made from card which will race down the F1 in Schools 24m roll out floor mounted track, powered by a 4g compressed gas Power Pack.

Or your car will be raced down the 10m Roll-Out Race Track using the Air Launch System and Pump.

Working as a team you must use a range of techniques to show design work, including freehand 3D sketches and card modelling skills.

TEAM ROLES:

TEAM MANAGER: The Team Manager will work closely with all members of the team, helping out where needed and keeping the team on track.

MANUFACTURING ENGINEER: The Manufacturing Engineer is responsible for making the car, based on the ideas of the Design Engineer.

DESIGN ENGINEER: The Design Engineer is responsible for designing an aerodynamic body shell for the car. The Design Engineer will need to discuss ideas with the Manufacturing Engineer to make sure that their ideas are possible.

GRAPHIC DESIGNER: The Graphic Designer is responsible for how the car looks and will oversee the design of the team's logo and uniform.

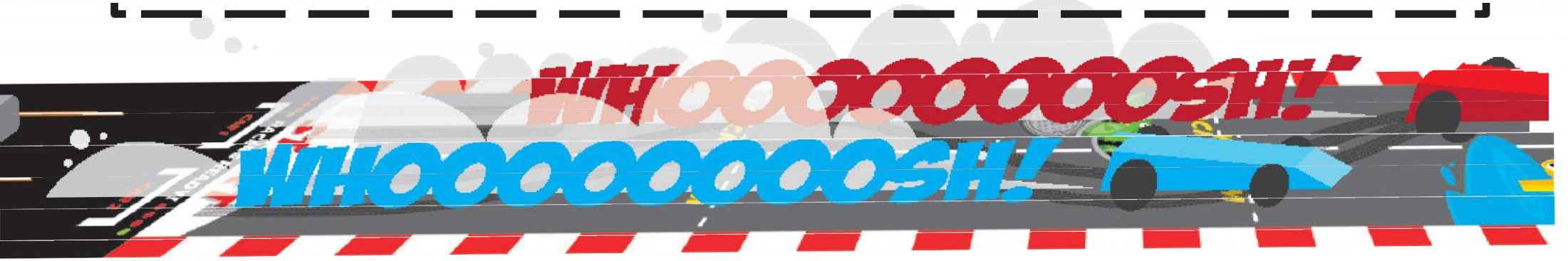

WHOOOOOSH!

WHOOOOOSH!

MEET THE TEAM

Decide on roles within your team and fill in the grid.

Say what qualities make you the right person for the job.

You could even add a picture of yourselves.

TEAM MANAGER

.....

MANUFACTURING ENGINEER

.....

DESIGN ENGINEER

.....

GRAPHIC DESIGNER

.....

WORKING AS A TEAM

To successfully compete in the F1 in Schools Mini Project you will need to work together as a team.

What qualities are important for good teamwork?
Try to think of 5 qualities which are important when working as a team.
Why are they important? List them below and explain why?



1

2

3

4

5

TEAMWORK

Using the words in the grid, fill in the blank spaces below.

WORK	LISTEN	PLAN	TEAM
TEAM MANAGER	TALK	HEARD	IDEAS

It is important to be able to share _ _ _ _ _ within your team. It is good to be able to _ _ _ _ , but you must also be prepared to _ _ _ _ _ to other people's opinions.

Don't be shy. When working as a team it is sometimes difficult to be _ _ _ _ . Everybody's opinion is important and should be considered before a decision is made.

It is a good idea to make a _ _ _ _ . **Set clear goals** and make sure that you stick to them.

Sometimes, when working as a team, tasks can get overlooked or repeated. It is the job of the _ _ _ _ _ to keep the team on track and make sure that all the jobs are done efficiently.

Each member of the team needs to contribute and do their fair share of the _ _ _ _ . Remember that you are a team and are there to help and support each other

Most of all, it is important to **have fun**. Any problems that arise should be solved as a _ _ _ _ .

BRAINSTORMING & MIND MAPS

Brainstorming is a group discussion to produce ideas or to solve problems. A good place to start is by creating a mind map. Mind maps are a way to explore a topic or idea. Start with a mind map heading. Write this in the middle of a piece of paper. Think of everything you can about the subject. You can go wild! Keep adding to the map until you have exhausted your ideas. Working this way can help you to generate new ideas.

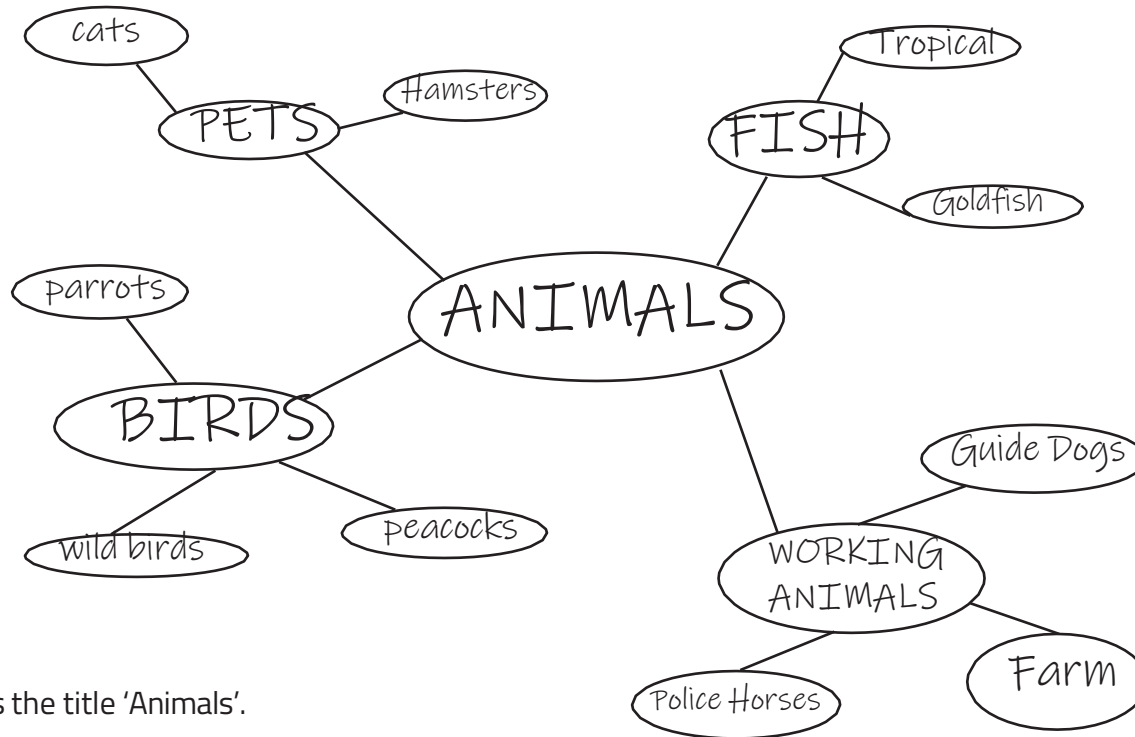

The mind map above explores the title 'Animals'.

Using a suitable title as a starting point create a mind map exploring a topic that will help generate ideas for a team name.

Starting points to consider:

SPEED	MOVEMENT	FORMULA 1	AERODYNAMIC	TEAMWORK	COLOURS
TRANSPORT	MYTHOLOGY	NATURE	SCIENCE	ELEMENTS	SPACE

.....or choose one of your own.

AERODYNAMICS

PAPER AEROPLANE CHALLENGE

An aeroplane in flight is acted on by four forces:

- LIFT**, the upward acting force
- GRAVITY**, the downward acting force
- THRUST**, the forward acting force
- DRAG**, the backward acting force (also called air resistance)

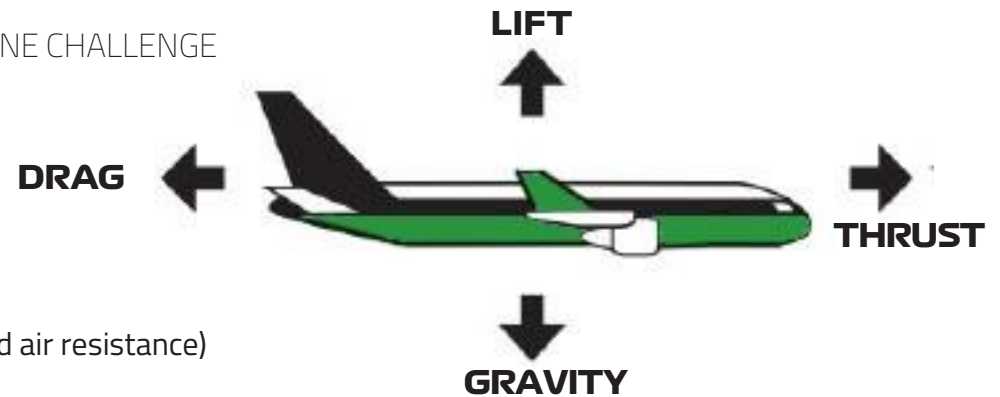

Drag and gravity are forces that act on anything lifted from the earth and moved through the air. Thrust and lift are artificially created forces used to overcome the forces of nature and enable an aeroplane to fly.

The aeroplane's engine and propeller combine to produce thrust to overcome drag. Their wings are designed to produce lift to overcome gravity.

Using a piece of paper make a basic paper aeroplane and nominate a pilot to fly the plane.

Think about...

Which directions would the different forces act upon a plane while it is in flight? What causes these forces?

How is thrust created to propel the paper plane?

To speed up a plane, which force would you increase?

Discuss with your team the forces that are acting upon the plane and whether those forces are thrust, drag, lift or gravity.

Consider how animals use forces to move faster or slower.

How do animals create the forces required for flight?

How does a streamlined shape affect the forces acting on different animals?

Think how weight can increase the effects of gravity. Elephants don't fly!

As a team discuss how the different forces will affect the performance of your car.

Can the information that you have learned help you to develop a faster car?

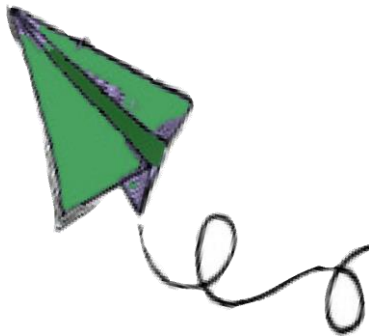

ISOMETRIC DRAWING

Isometric drawing is a method for visually representing three-dimensional objects in two dimensions in technical and engineering drawings.

An isometric drawing shows an object as if it is being viewed from above one corner. The axes being set out from this corner point. Start the Isometric drawing with a vertical line along which two points are defined. Any lines set out from these points should be at an angle of 30 degrees.

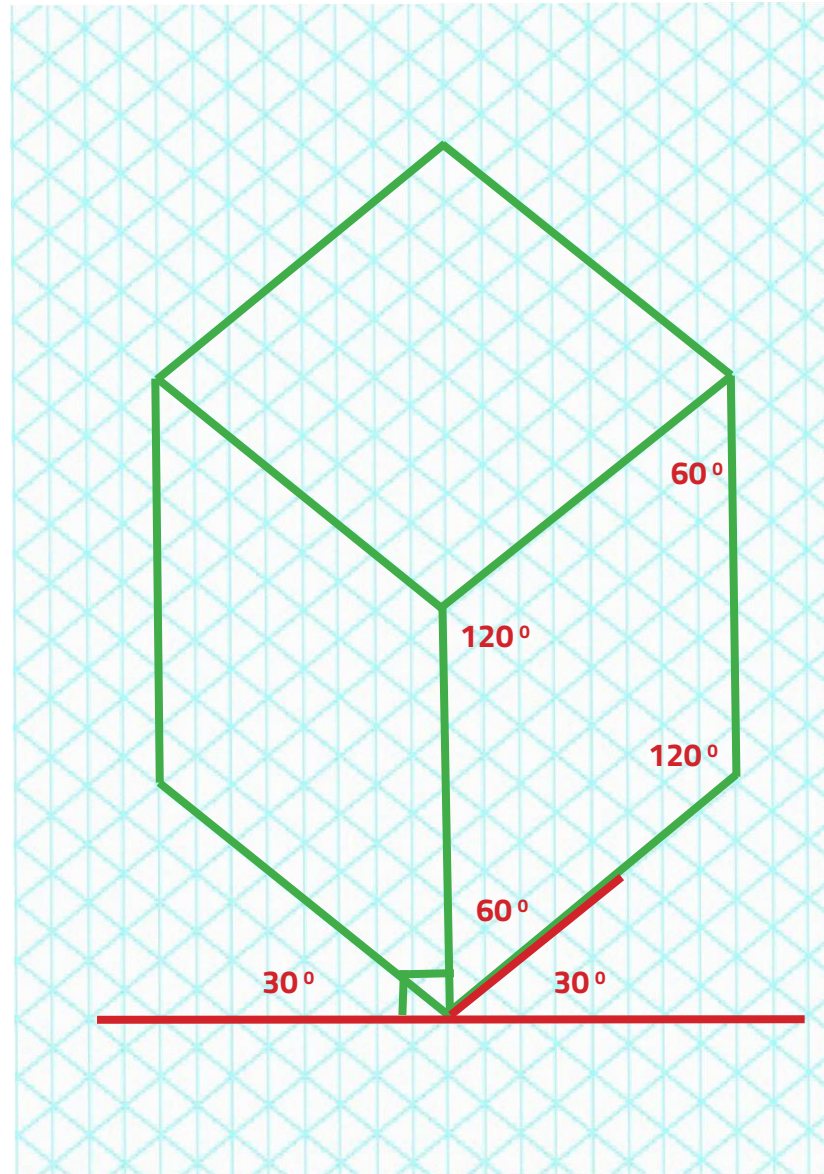

To create a isometric drawing you will need either a protractor, a specialist drawing tool, such as the IsoSketch, or isometric paper, to help you to construct the line and angles.

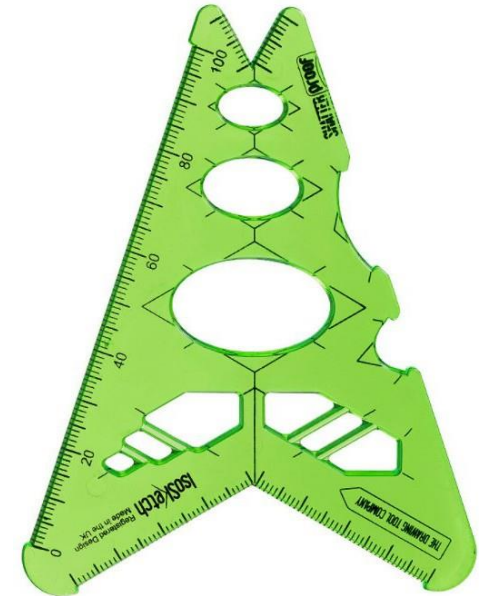

IsoSketch[®]
Isometric made easy

DESIGN IDEAS

OPTION 1

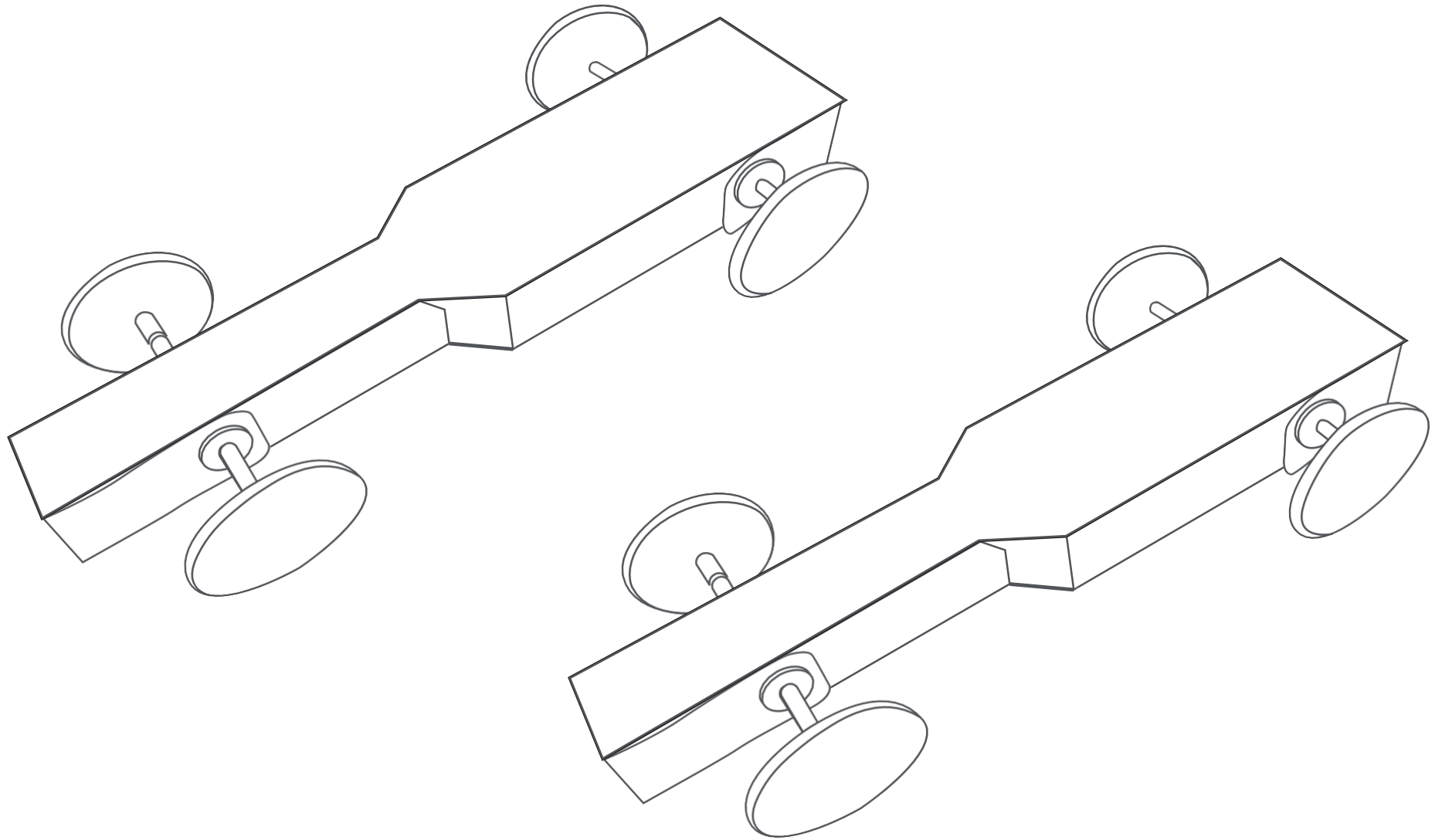

DESIGN IDEAS

OPTION 2

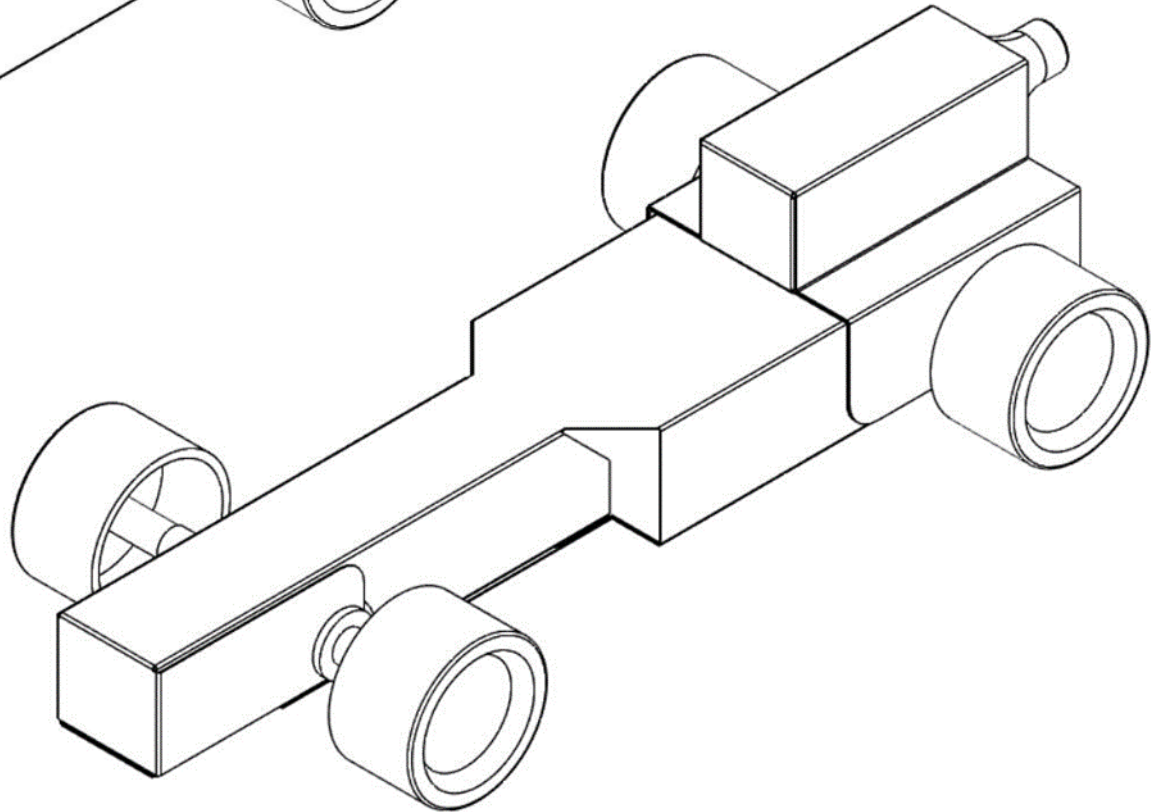
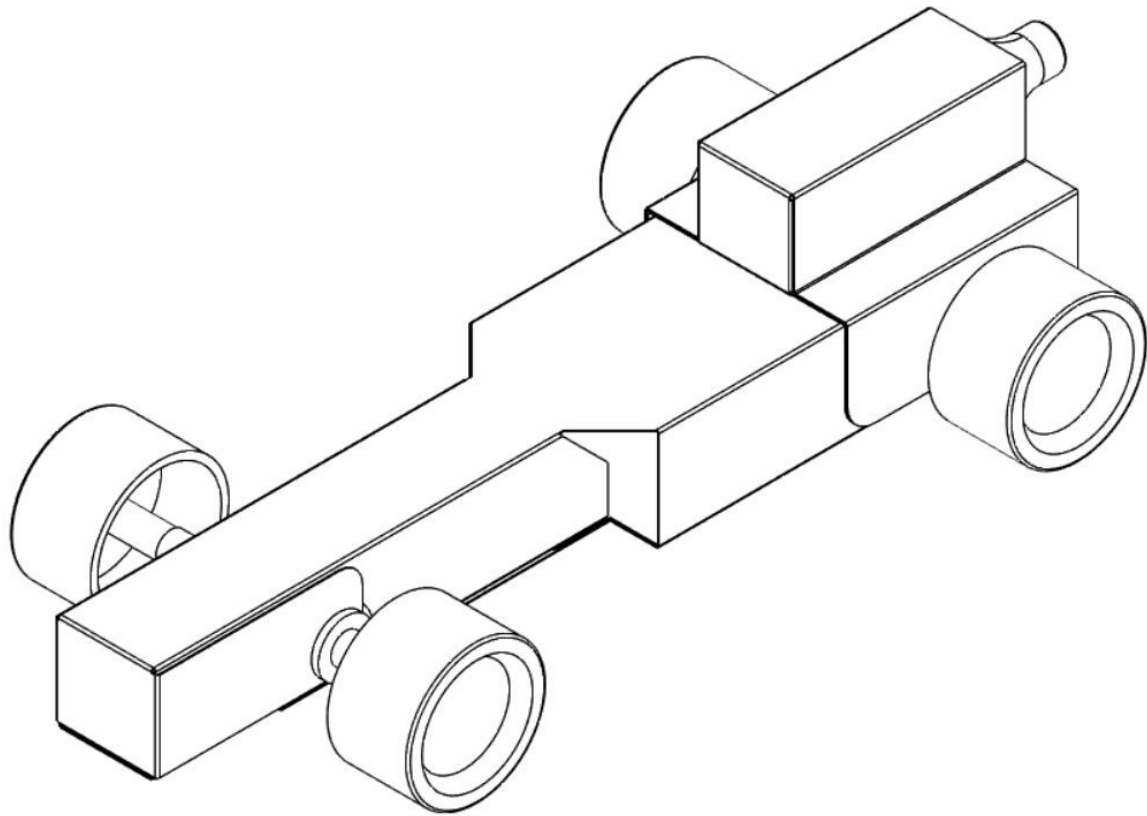

Air Pressure: Air is made up of molecules. Where there are lots of air molecules in a particular space, the air pressure is said to be high. If there are fewer air molecules in the same space, the air pressure is lower.

Air flows naturally from high to low pressure in order to equalize the air pressure.

Boundary layer: As air flows over the body of a car, the air is slowed down slightly due to the friction between the surface of the bodywork and the air. The amount that the air slows depends on the material that the body is made of - the smoother the surface of the car, the less friction there will be and the air flow will be slowed less.

The result of the air being slowed is that it has a slightly higher pressure than the rest of the air surrounding the car. The difference in air pressure means that the air does not follow the contours of the car as it tries to equalise the air pressure. This causes a negative effect on the forward speed of the car.

Drag

Energy is required to make a car move forward through the air and overcome drag. Drag is created in three main ways:

- **Frontal pressure** - the effect created by a car body pushing air out of the way.
- **Rear vacuum** - the effect created by air not being able to fill the hole created by the car body.
- **Boundary layer** - the effect of friction created by slow moving air at the surface of the vehicle body.

Drag, Lift & Downforce From Over Body Flow

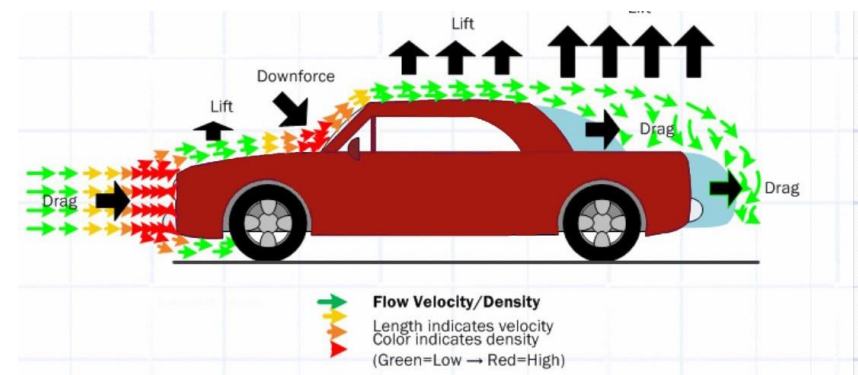

Frontal pressure is caused by air flowing around the front of a car. As the air reaches the front of the car it has nowhere to go, so becomes compressed, increasing the air pressure at that point.

Downforce and lift: In the real world, Formula 1 cars go so fast and the air flows over them in such a way that they are said to have too much lift and they have a tendency to take off into the air! As a result of this, designers have to add aerodynamic devices that create downforce so that the cars are pushed down onto the track and keep all four wheels on the ground. These devices create downforce by using the way the air flows over them to create areas of high air pressure that try to move to areas of low pressure.

REDUCING THE NEGATIVE IMPACT OF AIR RESISTANCE

Minimize frontal area

The larger the frontal area of a car, the more frontal pressure will be act against the forward movement of the speed. By reducing the frontal area the car will punch a smaller hole in the air it is travelling through. Reducing the frontal pressure in this way will result in better acceleration and a higher top speed.

Cover open wheels

Open, or uncovered wheels create a large amount of drag and air flow turbulence that will slow the car down. This can be reduced by covering the wheels with the body of the car.

Converge bodywork slowly

If the body of your car finishes suddenly or slopes steeply down toward the rear of the car, there will be a large rear vacuum effect and a lot of turbulence that will cause a lot of drag. This can be reduced by sloping the body gently down towards the rear of the car so that the air flows smoothly over the car.

Use spoilers

Spoilers create downforce by acting like a barrier to the air flow. Air cannot flow off the back of the car and is compressed in front of the spoiler. This compression means that there is higher air pressure in front. Adding a spoiler to a car design can provide downforce at the back of the car to help keep it on the track.

They are not as efficient as wings and if not designed carefully, can result in additional drag in the form of rear vacuum acting against the forward motion of the car.



THE PITCH

To be successful as a team, you will need to be able to present your ideas clearly and effectively.

Some people love talking. To others the idea of speaking in front of people can be a scary thought. Here are some helpful hints to make your pitch more successful.

**Speak clearly. Be careful not to talk too fast if you are nervous.
Use proper English, not slang.**

Make eye contact with the person/people that you are talking to. This will make them feel as though the pitch is directed at them.

If you are not confident when speaking to others, use note cards with bullet points to remind you of what you want to say. This looks better than reading the whole thing out.

Don't hide behind your notes. Take a deep breath, stand up tall and act with confidence (even if you don't feel it!)

Keep your pitch brief, to the point and make it interesting. Humour is a good way to break the ice and make everyone feel more relaxed.



Now it's your turn....

Each member of the team should choose an object (It could be anything from a baked bean can to a desk tidy!) Try to sell that object to the rest of the team.

Think of new uses for the object, be imaginative and present the best pitch that you can.

Remember:

Work together as a team and be respectful of the feelings of others.

Here are some more tips that can be used to help you construct a more persuasive pitch.....

TECHNIQUE	EXPLANATION	EXAMPLE
Flattery	Compliment your audience	"I'm sure that someone as well educated as you will have no problem in understanding...."
Address directly	Use the first person, I, you and we	"I believe that once you are in possession of all the facts you will make the right decision."
Rhetorical questions	A question that implies its own answer	"Do you want to succeed in this competition?"
Hyperbole	Exaggerated language used to create drama or make a point	"He could run faster than the wind"
Emotive language	Powerful words used to evoke emotion in your audience	"This is an incredible opportunity for you to be part of a group that saves the planet"
Triple facts	Three points to support your case	"To fulfil this role I will be organised, efficient and hard working."
Opinions	Present a personal opinion as if it were fact	"In my opinion, the best way forward is...."
Statistics	Factual data used in a persuasive way	"100% of this work will be completed ahead of time"
Imperative command	Instructional language	"You should do this...."

THE BUDGET

Money doesn't grow on trees

SHOPPING LIST

ITEM CODE	ITEM DESCRIPTION	PRICE PER ITEM (PITCOIN))	QUANTITY REQUIRED
SCK 1	Standard chassis kit (1x complete kit)	50PC	
CWA4	White A4 card (1 x sheet)	5PC	
CCA4	Coloured A4 card (1 sheet)	10PC	
BBC	1 x Plain Baseball Cap (if available)	25PC	
TSW	1 x Plain T-shirt (if available)	25PC	
PSS	1 X Printable Sticker Sheet	10PC	

Above is an example of a price list containing items that may be available to purchase using the 100 PTICOIN (**PC**)

As a team you have been given a 100**PC** start up fund.
What will you spend this money on?

F1 teams raise money through sponsorship.

Why would a company sponsor an F1 team?

What's in it for them?

Working as a team you will be given a budget of 100 PITCOIN (**PC**) to get you started.

You will need to raise additional finance to create your team identity and design and build your car.

Research and discuss the above as a team.

How can you raise the extra PITCOIN that you will need to produce the best racing car design and team identity?



SPONSORSHIP PACKAGES

Working as a team, you must deliver a sales pitch to sell the advertising space on your car to potential sponsors.

Create Bronze, Silver and Gold Packages. Each level of sponsorship package should offer more benefits than the one before, for a higher price.

Decide what to include in each package. It could include displaying the sponsor's name/logo on the car and/or uniform, giving the team or car a name associated with the sponsor, or promoting the sponsor in any other ways that you can think of.

Using your newly-acquired public speaking skills, pitch your sponsorship scheme to a potential sponsor. All members of the team must be involved in the presentation. It should last no more than 5 minutes and should highlight why YOUR TEAM is the best team to support and what you can offer potential sponsors.

Our Bronze Package will offer:

Our Silver Package will offer:

Our Gold Package will offer:

BUDGET SUMMARY

ITEMS	PITCOIN IN	PITCOIN OUT
TOTAL		

F1 TEAMS

Can you identify the following F1 team logos?



Match the team logos to the drivers on the next two pages.

Can you find out which companies sponsor the teams?

Think about the nationality of the driver and the country of origin of the team.

What other information can you find out relating to the driver or the team?

1



2



3



4



1

Name:

Age:

Team name:

Team sponsors:

Driving history:

2

Name:

Age:

Team name:

Team sponsors:

Driving history:

3

Name:

Age:

Team name:

Team sponsors:

Driving history:

4

Name:

Age:

Team name:

Team sponsors:

Driving history:

5



6



7



8



5

Name:

Age:

Team name:

Team sponsors:

Driving history:

6

Name:

Age:

Team name:

Team sponsors:

Driving history:

7

Name:

Age:

Team name:

Team sponsors:

Driving history:

8

Name:

Age:

Team name:

Team sponsors:

Driving history:

LOGOS

How many logos can you name?



- 1
- 2
- 3
- 4
- 5
- 6
- 7
- 8
- 9
- 10
- 11
- 12
- 13
- 14
- 15
- 16
- 17
- 18
- 19
- 20
- 21
- 22
- 23
- 24
- 25
- 26
- 27

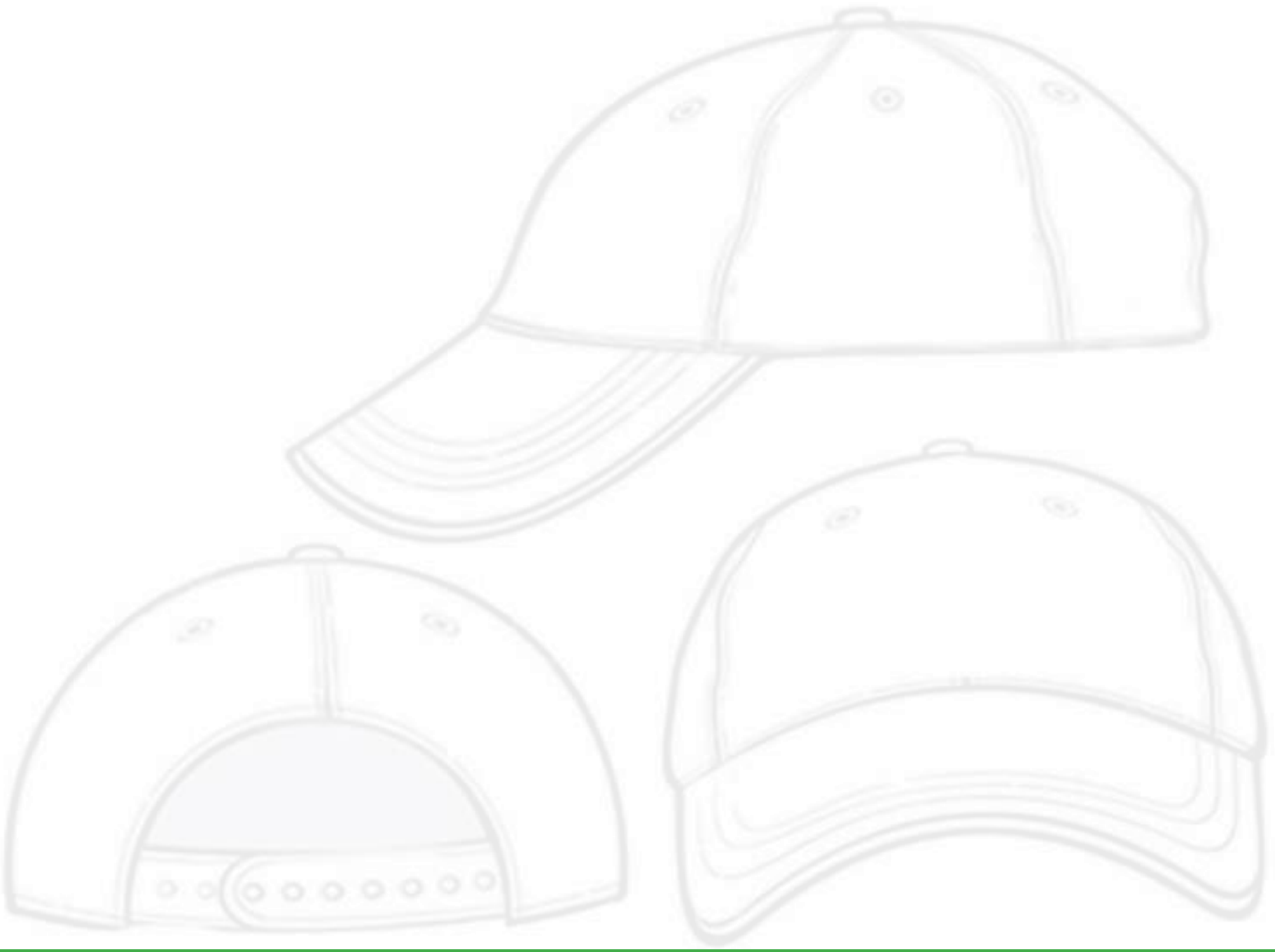

DESIGN A BASEBALL CAP

**DESIGN A T-
SHIRT**



TESTING

A Wind tunnel is structure used for studying how airstreams behave when passing over a solid object. Wind tunnels produce a high-speed airstream, which flows, passing over the model being tested. The model is fixed inside testing area of the tunnel so that lift and drag forces on it can be measured.

Smoke-like vapour can be added to the air streams to clearly show the air stream patterns



Test the aerodynamic qualities of your car using a Denford Air Trace Visualisation System and Air Trace Smoke Generator. If you do not have access to this equipment, you can develop your own wind/smoke tunnel. Ideas and suggestions can be found on line. You could use a hair dryer and drinking straws to focus the air streams. Air streams can be highlighted using chalk spray paint. Alternatively, a simple air trace unit can be created using building bricks to construct a frame supporting thin ribbons. Use a hair dryer to blow the ribbons over the car. This will show the pattern of the air flow.

To minimise friction wheel alignment can be tested by constructing a small ramp and observing the path of your car when free rolling.

WORDSEARCH

G	N	I	R	A	C	O	K	R	O	W	M	A	E	T
N	R	A	K	K	O	D	N	A	L	O	P	X	E	E
I	N	A	T	A	E	I	O	C	O	R	U	S	P	A
N	U	F	P	R	C	O	N	E	C	P	T	P	A	M
N	O	L	E	H	S	S	E	N	O	O	P	V	C	M
A	G	W	L	L	I	S	T	E	N	R	L	I	O	A
L	O	C	O	M	O	C	I	N	N	T	R	C	N	T
P	I	N	G	I	S	E	D	I	I	F	A	T	S	E
O	L	D	O	V	E	D	O	E	P	O	C	O	T	S
S	Y	R	A	M	I	R	P	S	S	L	I	N	R	R
M	A	N	U	F	A	C	T	U	R	I	N	G	U	D
S	M	R	E	E	N	I	G	N	E	O	G	I	C	E
F	E	I	R	B	N	G	I	S	E	D	C	N	T	C
A	C	I	M	A	N	Y	D	O	R	E	A	O	E	A
F	O	R	M	U	L	A	O	N	E	R	R	B	D	R

TEAMMATES
DESIGN BRIEF
GRAPHIC DESIGNER
MANUFACTURING
FORMULA ONE
PORTFOLIO
TEAMWORK
CONSTRUCTED
RACING CAR
AERODYNAMIC
TEST
RACE
PRIMARY
LOGO
LISTEN
FUN
POWERED
ENGINEER
PLANNING

RULES & REGULATIONS

Overall body length - Min: 200mm / Max: 250mm

The total length, measured between the front and rear extremities of the car, including any styling features.

Overall body width - Max: 80mm

The overall body width at its widest part should not exceed 80mm.

Total car weight - Min: 40g

The minimum weight the complete car must be to race, including wheels, axles, stickers etc.

Car construction material -

Only card should be used to manufacture the car chassis, engine housing, body and wings.

Graphics -

To make your car easy to identify, some graphic (visual) elements should be clearly displayed on the car. These must include the team name / team logo.

Portfolio of work-

You must produce a 5-page (10 sides) Design & Engineering Portfolio. This should explain how you designed, tested and made your F1 in Schools racing car.

Your Design & Engineering Portfolio should contain evidence of the following:

- **Initial ideas** – including 3D freehand sketches
- **Design development** – including images of any models and testing
- **Team Graphic Identity** – including team name, logo and car livery (colour scheme and patterns)
- **Manufacturing** – including photos and descriptions of how you cut and assembled the parts of your race car
- **Testing** – showing / explaining how you tested your car, what you found out and what you then changed
- **Project Management** – who did what, how you planned your time and how you think it turned out (good and bad!)
- **Budget Summary-** showing how much PITCOIN was spent on each part of the project and how the PITCOIN was aquired.

You may choose to include the following sections, which do NOT count towards your 5-page limit:

- Decorative front cover
- Contents page

Note: You MUST clearly display your team's name on the front page of your Design & Engineering Portfolio.